

# SCIENTIFIC, TECHNICAL AND VOCATIONAL EDUCATION OF GIRLS IN AFRICA

Science Experiments

by

Julie Ladel and Jérôme Thibault

Section for Science and Technology Education  
Section for Technical and Vocational Education  
Working document 1999

**Contact:**

Anna Maria Hoffmann-Barthes  
Programme Specialist  
Section for Science and Technology Education  
UNESCO  
7, place de Fontenoy  
F-75352 Paris 07SP  
Fax. +33-145685622  
Email [AM.BARTHES@UNESCO.ORG](mailto:AM.BARTHES@UNESCO.ORG)

# CONTENTS

<b>Preface</b>	<b>1</b>
<b>Guidelines</b>	<b>3</b>
Presentation of the activities	3
Sequencing within a theme	3
Objectives of the activities proposed	3
Guidelines for the development of new activities	4
Activities' preparation by the educator	4
Preliminary adaptation of material	5
Preliminary adaptation and product storage	6
<b>Science education activities</b>	<b>9</b>
Washing with water	9
W1 Does water wet well?	9
W2 Does water have a "skin"?	10
W3 Does water mix with other products	11
W4 Interest of detergents	12
W5 Clothes washing	13
Making cosmetics	15
C1 Make-up preparation	15
C2 Lipstick preparation	16
C3 Toothpaste preparation	17
C4 Soap preparation	18
Learning with a soap film	19
S1 Soap bubbles liquid preparation	19
S2 A soap film	20
S3 Soap film elasticity	21
S4 Minimal surfaces and soap film	21
S5 Self-cicatrization of soap film	22
S6 Soap film and bubbles iridescence	22
Using solar energy	23
E1 Solar energy	23
E2 Building a solar oven	24
E3 Building of a solar water-heater	25
E4 Salt water desalinization	26
Making or recycling materials	27
M1 Making buttons from milk	27
M2 Making a brooch of synthetic resin	28
M3 Making a plastic film	29
M4 Making a polyurethane foam	30
M5 Recycling paper	31
<b>Further reading</b>	<b>33</b>

## PREFACE

UNESCO's current Medium-Term Strategy (1996-2001) designated Women and Africa as priority target groups for action. In this context, a six-year ***Special Project on Scientific, Technical and Vocational Education of Girls in Africa*** was launched in 1996 with the aim to reduce gender disparities in this field. This is a joint project of the Section for Science and Technology Education and the Section for Technical and Vocational Education, undertaken in close co-operation with international, regional and national governmental and non-governmental organizations.

The overall objectives of the project are:

1. To improve the access of girls to scientific, technical and vocational education (STVE);
2. To break the barriers for girls in secondary school, notably by improving the quality and effectiveness of STVE;
3. To make an impact on the attitudes and stereotypes of teachers, which prevent girls from taking advantage of current opportunities in science and technology;
4. To promote a positive image of women in scientific and technical careers;
5. To sensitize policy makers, parents, employers and the general public about the ways in which women's full participation in science and technology can make a positive difference for current and future generations.

The present document specifically covers science education, and attempts to provide examples of science experiments specially prepared and selected to raise the interest of girls towards sciences and in the long-term motivate them towards science and technology education and related careers.

The key-place of science and technology in our society today requires **scientific and technological literacy for all**. Science and technology education activities should thus give the opportunity for all - children, teenagers and adults, male and female - to discover or revise basic notions which enable a better understanding of the world. However, the content of, and examples and illustrations in many science-related curricula and other educational materials tend to build more on the experiences of boys and ignore those of the girls.

The concepts and principles of science and technology education are universal, however, the way they are presented and illustrated should be put into a gender-sensitive and cultural context to facilitate understanding and teaching from the known to the unknown for all, both girls and boys.

While a lot of science and technology (S&T) is encountered in the home, and particularly in the kitchen, this fact is hardly ever used to introduce concepts/topics such as Heat and Temperature, Solubility and Solutions, Prevention of Rusting, Food Preservation as well as Waste Management and Disposal. Similarly, a lot of technology at the basic level can be taught starting from activities and experiences of girls, in addition to those of boys. For example the concept of appropriate technology can be taught using examples of labour-saving and timesaving devices that are of direct assistance and hence interest to girls like energy-conserving stoves, water pumps and heaters.

This document proposes experimental scientific and technological low-cost activities on topical issues related to daily life, that can be adapted by educators to the local context or enriched with activities based on their own experience. Guidelines can be found in the following chapter to help in their implementation and development.

Most of these activities have been elaborated from the work and experience of the Association "Graine de Chimiste" from the University of Paris (France). In France, Belgium and Portugal, this Association has introduced more than 50,000 people, children from 5 years and above, teenagers and adults, in formal and non formal contexts, to hands-on experiments, giving gestural and scientific knowledge and skills.

In the medium-term, the objective is to enrich this document in order to publish a more complete resource kit on gender sensitive science activities. Experiments that you would like to add can be submitted to:

Section for Science and Technology Education (ED/SVE/STE)  
UNESCO  
7, place Fontenoy  
75352 Paris 07 SP  
France

## GUIDELINES

### Presentation of the activities

The activities, presented in reproducible sheets, can be implemented in formal and non-formal contexts with participants from 10 to 16 years old. Most of the activity sheets can also be adapted for a younger public target, from 5 years and above.

All activity sheets are presented with the same format, comprising:

- the **activity title**, its **duration**, its individual or group **implementation**
- a detailed **experimental protocol** to implement the activity (required products and materials list, possible special care to be taken, operating procedure to be scrupulously followed)
- a **synthesis of observations**
- **remarks** about important notions or to widen the activity field

Activities are divided in five parts which can be dealt with separately and adapted to the participants level and to material conditions:

- 5 activities (L1 to L5) to show that "**Washing with water**",
- 3 activities (C1 to C4) to "**Making cosmetics**",
- 6 activities (S1 to S6) to "**Learning with a soap film**",
- 3 activities (E1 to E3) to "**Using renewable energies**",
- 3 activities (M1 to M5) to "**Making or recycle materials**".

Certain activities are more adapted for group implementation and others for individual implementation. For each activity, "duration" and "individual" or "in group" notes will enable the educator to organize the sessions.

### Sequencing within a theme

The sequencing proposed for each of the five parts is due to a progression in transdisciplinary scientific notions tackled or to an approach based on daily life to explain more complex phenomena. In an educational perspective, the session can be re-organized depending on the educator's objectives.

## **Objectives of the activities proposed**

All activities are proposed for individual implementation by the participants, under the supervision of the educator, who will organize the exchange of results, theoretical and practical inputs and animate the discussions.

Undertaking the activities with respect to hygiene and security and with a “scientific protocol” (the activity sheets) help to create a rigorous and confident climate required for scientific experimentation.

The educator could also support initiatives of the participants to develop activities themselves and induce the writing of experimental protocols on topics close to participants, before implementation and discussion on the experiment (security, operating difficulties, theoretical difficulties, etc.).

Depending on the educational objectives, the activities evaluation should consider either manipulative skills, conceptual or methodological acquisitions.

## **Guidelines for the development of new activities**

A complete science and technology education can not only consist in transmitting information and existing solutions only, but should lead to the acquisition of values, knowledge and skills, and a also critical mind, all of which is useful in daily life.

The most pertinent activities deal with the participants' affective environment and enable them to perceive the world differently. Concepts and principles, experimental methods and technology mastery are only tools that contribute to the understanding of natural phenomenon, general or topical processes and usual practices.

Examples of activities topics are among others the universe and natural laws perception, the environment in its globality, the living organisms behavior and their belongingness to ecosystems, health, the infinitely little discovery, the processes involved in cooking, washing, do-it-yourself, genetics, bionic, mechanics, renewable energies, materials knowledge, new technologies.

## **Activities' preparation by the educator**

The pre-implementation of each experimental activity is highly recommended, to enable the educator to anticipate the material difficulties,

find solutions to the problems faced and to prepare the organization and the development of the session.

For indication, the preparation comprises the following steps:

- **activity material adaptation** by the educator (supply of material and products depending on local conditions); if possible, as any participant implement the activity individually, material and products should be planned for all.
- **implementation** of the **activity** by the educator
- **information search** for the educator to anticipate questions or difficulties to be explained to participants
- **talk preparation and activity organization** (including experimental, discussion and thought periods)
- **activity developments preparation** (preparation of an exhibition or a survey, industrial site visit, article writing, professionals meeting, etc.)

For hygiene, security and pedagogy reasons, any participant shall:

- dispose of his/her own **material** and **products**
- wear **clean cotton clothes** reserved for experimentation
- wash his/her **hands** before and after hands-on activities
- tie **long hair**
- wear **gloves** and **goggles** for activity M2 which requires products.

The respect of these few precautions will guarantee a good progress of experimental activities.



## Preliminary adaptation of material

The handled material is obtained, as possible, from daily life objects with minimum risk and adapted (wood or plastic objects instead of glass). The following, in bold, are the materials mentioned in the activity-sheets experimental protocols, which can be replaced, if necessary, by the materials in brackets:

- **a box** (in plastic, in cardboard)
- **a car headlight reflector**
- **a clothes line, clothes pins**
- **a filter** (a paper filter at the funnel's size, a absorbent cotton make-up remover ring, a bit of absorbent cotton to block a funnel)
- **a flask** (a dropper sold in pharmacies, or a vessel or yoghurt pot together with a non-graduated pipette or a straw only to be used with the finger and not with the mouth)
- **a funnel** (a plastic funnel, a box with smaller holes than the filter, the neck of a water bottle)
- **glass tubes**
- **a grille** (a device made of wire netting, an oven grille)
- **a measure** (a milk or coffee measure, a teaspoon, a soup-spoon - previously standardized with the solid to be withdrawn)
- **a measuring cylinder** (a plastic measuring cylinder, a known volume vessel consisting of a little water bottle, a tube or other vessel standardized before with a know volume of water)
- **a mirror** (a pocket mirror, light reflecting surface)
- **paper hankies:** cotton piece of rag
- **old papers**
- **a plastic foil:** a stretchable food film, a plastic bag
- **a plastic tube**
- **a piece of plate glass**
- **a pot** (a cleaned yoghurt vessel, a water bottle bottom or a glass vessel, a photographic film packaging)
- **a roller** (a rolling pin, a bottle)
- **screws, washers**
- **a spatula** (a spatula sold in pharmacies, a spoon or its handle, a cleaned ice cream stick)
- **a stick** (a toothpick, a skewer pick)
- **a stopper** (a cork, a water bottle stopper)
- **a stove** (a hotplate)
- **a tank, a cup, a plate** (half a Petri dish, a heatproof dish or plate (Pyrex))
- **an alcohol thermometer** (a mercury thermometer – remembering that mercury is toxic)

- a **thin tissue** (cotton or muslin fabric)
- a **trapeze** (a device made of soldered metallic rods and sewing thread)
- a **wash-bottle** (a plastic wash-bottle, a plugged water bottle)
- a **wooden board, wood tassels**

### **Preliminary adaptation and product storage**

All products should be packaged in plugged flasks labeled with the product's name. For hygiene and/or security, never touch, smell nor taste a product (except for particular cases like tasting drinking waters). Most products required for the proposed activities are usual products. Solid ones are bottled in broad plugged flasks and liquid ones in plugged dropper-flasks or bottles to take them easily and safely.

The following products can be found in alimentary shops:

- |   |                         |
|---|-------------------------|
| • water (tap water)                               | stored in a wash-bottle |
| • demineralized water (water for batteries)       | stored in a wash-bottle |
| • salt, pepper, colorant                          | stored in vessels       |
| • oil, aroma, perfume, milk, lemon juice, vinegar | stored in a flask       |
| • ice   | stored in a tank        |

The following products can be found in do-it-yourself shops:

- |   |                         |
|---|-------------------------|
| • Liquid detergent (liquid soap)          | stored in a flask       |
| • Black paint                             |                         |
| • glue                                    |                         |
| • MDI : 4-4' diphenylmethane diisocyanate | stored in its packaging |
| • polyol and expansion agent mixture      | stored in its packaging |

The following products can be found at pharmacies or laboratory suppliers:

- Liquids stored in flacon: isopropyle myristate, glycerin, ethanol, fluoride de sodium (40g.l-1 solution), sodium hydroxide(10 cm<sup>3</sup> of solution 3 mol.l-1) sodium chloride (for the soap : saturated salt solution in demineralized water), formaldehyde, concentrated hydrochloric acid.
- Solids stored in pots: bees wax, lanolin, talc, preservative (propyle parahydroxybenzoate, facultative), cellulose, silica gel, sodium dodecyle sulfate, urea, polyvinyl alcohol (PVA).

# Washing with water

**W1. does water wet well ?** (duration: about 15 minutes - individual)

**products**

- water
- liquid detergent

**material**

- 1 plastic foil  
or 1 piece of dry  
tissue

**operating procedure**

- 1- lay 2 distant water drops down the selected support
- 2- observe water drop s form
- 3- add 5 water drop s to form a big one
- 4- add 4 water drop s and 1 drop of liquid detergent
- 5- observe

**observations**

- Draw what you have obtained at the end of the experiment.

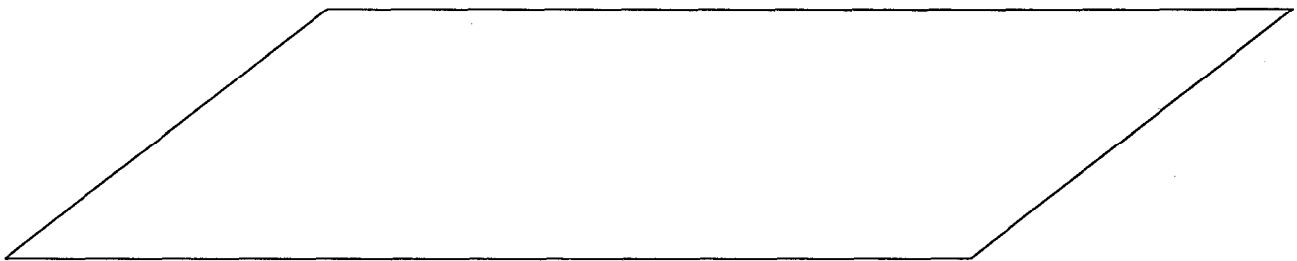

- Try to wet your hand with a few water drops. What do you observe?

.....

**remarks**

- Cross what is wrong:  
(The wetting power of a liquid is its ability to wet a surface.)

Water has a good/bad wetting power.

A detergent increase/decrease water wetting power.

- What is a detergent?

.....

- Which detergents do you know?

.....

- Which detergents do you use at home?

.....

- Why do you use detergents?

.....

# Washing with water

## W2. Does water have a "skin"?

(duration: about 15 minutes - individual)

### products

- water
- liquid detergent

### material

- 2 pots
- 2 cups

### operating procedure

- 1- fill to the brim 2 pots placed on a cup with water
- 2- add in each pot 40 additional water drop s to form a meniscus
- 3- add 1 additional water drop in pot n°1
- 4- add 1 drop of liquid detergent in pot n°2
- 5- observe

### observations

- Draw what you have obtained at the end of the experiment.

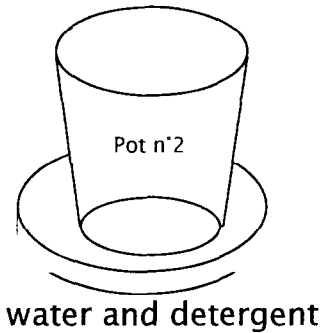
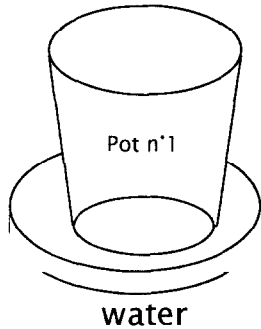

- What happened in the drink of water?.....
- What happened in the drink of water to which detergent has been added? .....

### Remarks

- Water seems maintained by a stretched "skin" which prevent its overflow from the pot. It is under a surface tension, that is a force which pulls its surface to the inside: water is encountered by water avoiding as possible contact with air.
- Cross what is wrong off: A detergent increase/decrease water surface tension as water surface has increased/decreased and so its elasticity.
- Water is the liquid with the highest surface tension, except liquid metals such as mercury.
- A detergent is called surface-active as it changes liquids surface tension.
- Surface-actives chemicals such as detergents (schematized by ) are made of one part that likes water (or hydrophilic ) and another one that shuns water (or hydrophobic ). They enable by this way the association of hydrophobic chemicals to water. Draw how will the detergent be placed at the water surface and in contact with the air, using graphical standards defined above.

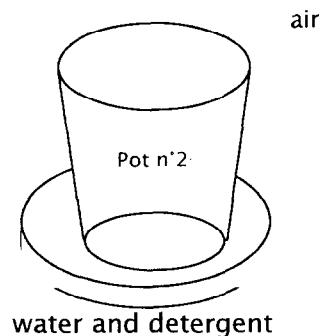

# Water is not sufficient to wash

## W3. Water mixes to certain products

(duration: about 45 minutes - individual)

### products

- water
- oil
- coloring
- salt
- pepper (or talc)

### material

- 4 pots
- 4 spatulas
- 2 measuring cylinders of 10 cm<sup>3</sup>
- 1 measuring cylinder of 50 cm<sup>3</sup>
- 2 measures (equivalent to 3g of each solid)

### operating procedure

- 1- take 10 cm<sup>3</sup> oil with a 10 cm<sup>3</sup> measuring cylinder
- 2- pour oil in a clean pot
- 3- take 50 cm<sup>3</sup> water with a 50 cm<sup>3</sup> measuring cylinder
- 4- pour water in the pot
- 5- mix with spatula and observe
- 6- do this experiment again with 10 cm<sup>3</sup> coloring and clean material
- 7- add 1 skimmed measure of salt in a clean pot
- 8- take 50 cm<sup>3</sup> water with a 50 cm<sup>3</sup> measuring cylinder
- 9- pour water in the pot
- 10- mix with spatula and observe
- 11- do this experiment again with 1 skimmed measure of pepper and clean material

### observations

- When products that form a mixture can not be distinguished, the mixture is homogeneous. When products that form a mixture can be distinguished, the mixture is heterogeneous.
- Two liquids that form a homogeneous mixture are miscible. Two liquids that form a heterogeneous mixture are non miscible.
- A solid that forms a homogeneous mixture with a liquid is soluble in this liquid. A solid that forms a heterogeneous mixture with a liquid is insoluble in this liquid.
- Draw what you observe in each pot after mixture and cross what is wrong:

Mixture: water and oil   water and coloring   water and salt   water and pepper

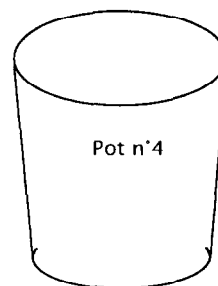
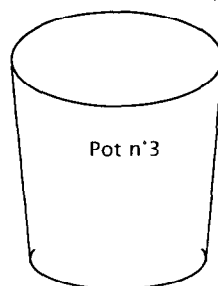
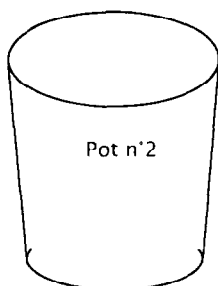
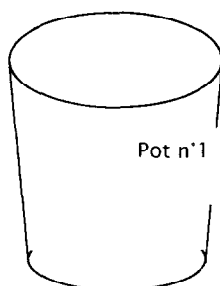

this mixture is

homogeneous  
heterogeneous

homogeneous  
heterogeneous

homogeneous  
heterogeneous

homogeneous  
heterogeneous

oil is :

miscible to water  
non miscible  
soluble in water  
insoluble in water

the coloring is :

miscible to water  
non miscible  
soluble in water  
insoluble in water

the salt is :

miscible to water  
non miscible  
soluble in water  
insoluble in water

the pepper is :

miscible to water  
non miscible  
soluble in water  
insoluble in water

### remarks

- Water (natural, demineralized, distilled) is not a pure corps: on contact with the atmosphere, water dissolves existing gases (diazote, dioxygene, carbone dioxyde, etc.). By rocks dissolution, it may also carry various mineral substances (calcium carbonate (limestone), calcium sulfate (gypsum)). One can not talk about pure water.
- Water pollution results from the introduction of substances that were either absent (synthetic products), or present in lower quantities (nitrates, phósphates, etc.) in natural waters.

# Water is not sufficient to wash

## W4. Interest of detergents

(duration: about 30 minutes - individual)

### products

- water
- liquid detergent
- oil
- pepper (or talc)

### material

- 4 pots
- 1 measuring cylinder of 10 cm<sup>3</sup>
- 1 measuring cylinder of 20 cm<sup>3</sup>
- 5 spatulas
- 2 dropper-flasks

### operating procedure

#### non miscible liquids dispersion in water

- 1- measure 20 cm<sup>3</sup> of water with a measuring cylinder
- 2- pour into pot n°1
- 3- measure 10 cm<sup>3</sup> of oil with a clean measuring cylinder
- 4- pour into pot n°1 and observe
- 5- prepare as above another mixture in pot n°2
- 6- add 20 water drop s in pot n°1
- 7- mix with a spatula the content of pot n°1 and observe
- 8- add 20 drops of liquid detergent in pot n°2
- 9- mix with a spatula the content of pot n°2 and observe

#### insoluble solids dispersion in water

- 10- fill pots n°3 and 4 with water
- 11- add 1 hint of spatula of pepper in each pot
- 12- observe
- 13- add 1 water drop in pot n°3
- 14- mix with a spatula the content of pot n°3 and observe
- 15- add 1 drop of liquid detergent in pot n°4
- 16- mix with a spatula the content of pot n°4 and observe

### observations

- Draw what you observe at the end of the experiment.

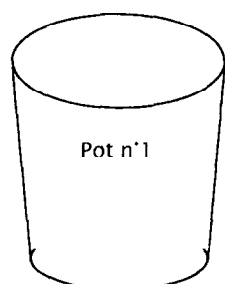

water and oil

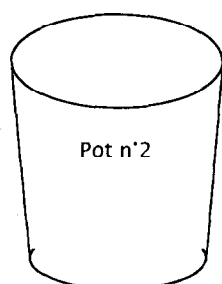

water, oil and detergent

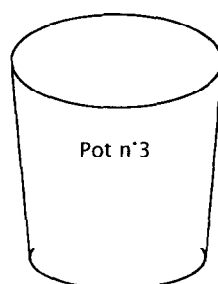

water and pepper

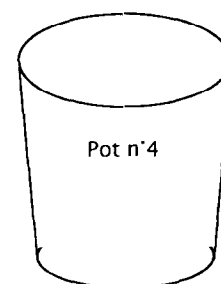

water, pepper and detergent

### remarks

- What is the detergent role in this experiment?

- Insoluble or non miscible products dispersion in water is increased when clothes are beaten.
- Indicate your colors(  ) and schematize how you imagine products in relation to the others within the mixture:

water

detergent

oil

pepper

water, oil and detergent

water, pepper and detergent

# Washing with water

## W5. Clothes washing

(duration: about 30 minutes - individual and in group)

### questionnaire

- Clothes can be dirtied by several kinds of dirt.  
Indicate examples of dirt: .....
- Indicate, for each example, dirt properties (solid/liquid ; soluble/insoluble in water or miscible/non miscible with water ; hydrophilic/hydrophobic):
  - sugar: .....
  - dust (see experiment with pepper): .....
  - blood: .....
  - salt: .....
  - oil (or other fats): .....
  - coloring: .....
- During washing, soluble and insoluble products in water, miscible and non miscible to water are eliminated. Indicate the case(s) where the use of detergent is necessary.
  - a product soluble in water is eliminated with/without detergent (example : .....)
  - a product insoluble in water is eliminated with/without detergent (example : .....)
  - a product miscible to water is eliminated with/without detergent (example : .....)
  - a product non miscible to water is eliminated with/without detergent (example : .....)
- Cloth washing is decomposed of five steps (rinse, wet, wringing, washing in itself (use of detergent), beating). Indicate the washing steps name in chronological order:
  - first step : .....
  - second step : .....
  - third step : .....
  - forth step : .....
  - fifth step : .....

### remarks

- Blood is a red liquid composed of plasma and corps in suspension in plasma (red corpuscles, white corpuscles, plaques). Plasma carries lots of dissolved substances such as mineral salts, proteins (e.g. albumin), lipids (or "fats"), sugars and wastes from living organisms functioning.
- Substances such as blood which contain proteins, organic substances present in any living bodies, are heavy and difficult to carry by detergents. Modern washing powders comprise enzymes, biological substances of protein nature, with the characteristic to decompose certain proteins in smaller pieces. These pieces are thereafter easier to be eliminated by detergents.

# Making cosmetics

## CI. Make-up preparation

(duration: about 1 hour - individual)

### products

- bees wax
- lanolin
- talc
- preservative (facultative)
- coloring (facultative)

### material

- 1 tank for boiling water
- 1 stove
- 2 spatulas
- 1 pot
- 1 soup-spoon (lanolin)
- 1 stopped flask
- 1 label sticker

### operating procedure

1. **prepare** boiling water by heating water in a resistant tank placed on a stove
2. **switch** the stove on
3. **put** with a spatula 12 grains of bees wax in a pot
4. **skim** 1 tablespoonful of lanolin with a clean spatula
5. **place** the soup-spoon in the pot
6. **place** the pot in the boiling water
7. **wait** till the pot content has completely melt
8. **remove** the pot from the boiling water
9. **add** 1 hint of spatula of preservative (facultative)
10. **add** 2 skimmed measures of talc with the clean spatula
11. **mix**
12. **add** 40 drops of coloring (facultative)
13. **place** the pot in boiling water again (about 1 minute)
14. **remove** the pot from boiling water
15. **switch** the stove off
16. **mix** the pot content
17. **for** into the pot content in a flask
18. **block** and label this flask

### remarks

- Cosmetics are non medicinal substances or preparations aimed at body care, wash, beauty. They are on contact with teeth, mucous and other external parts of the body. They are used to wash (detergents), protect, maintain in fit state, modify the aspect, perfume, ...
- Make-up is a homogeneous mixture of several products. Depending on the coloring, different make-up can be prepared with selected colors.
- Bees wax (1 grain=1g) and lanolin are fatty products that constitute the make-up base.
- Talc is used for hiding imperfections during the make-up spreading on the face and gives a mat aspect.
- The coloring determines the color and the preservative avoids mould development.



# Making cosmetics

## C2. Lipstick preparation

(duration: about 1 hour - individual)

### products

- castor oil
- bees wax (5 grains=5 g)
- isopropyl myristate
- lanolin
- preservative (facultative)
- coloring (facultative)

### material

- 1 tank for boiling water
- 1 stove
- 1 measuring cylinder of 25 cm<sup>3</sup>
- 2 spatulas
- 1 pot
- 1 measuring cylinder of 10 cm<sup>3</sup>
- 1 measure (10 g of lanolin)
- 1 measure (1g of coloring)
- 1 stopped flask
- 1 label sticker

### operating procedure

- 1- **prepare** a boiling water by heating water in a resistant tank placed on a stove
- 2- **switch** the stove on
- 3- **measure** 11 cm<sup>3</sup> of castor oil with the 25 cm<sup>3</sup> measuring cylinder
- 4- **pour** into the pot
- 5- **add** with a spatula 5 grains of bees wax in pot
- 6- **measure** 2 cm<sup>3</sup> of isopropyl myristate with 10 cm<sup>3</sup> measuring cylinder
- 7- **pour** into the pot
- 8- **add** 1 skimmed measure of lanolin with a second spatula
- 9- **add** 1 hint of spatula of preservative (facultative)
- 10- **place** the pot in the boiling water
- 11- **wait** till waxes have completely melt
- 12- **remove** the pot from boiling water
- 13- **add** with the clean spatula 1 skimmed measure of coloring (facultative)
- 14- **carefully mix** with the spatula till a homogeneous mixture is obtained
- 15- **place** the pot in the boiling water again (about 1 minute)
- 16- **switch** the stove off
- 17- **remove** the pot from boiling water
- 18- **carefully mix** the pot content
- 19- **pour** the pot content into the flask
- 20- **block and label** this flask

### remarks

- The prepared lipstick is a **homogeneous mixture** of several products.
- Castor oil, **bees wax** and **lanolin** are fatty products that constitute the lipstick base.
- Isopropyl myristate gives the lipstick shiny aspect, the coloring determines its color and the preservative avoids mould development.

# Making cosmetics

## C3. Toothpaste preparation

(duration: about 1 hour - individual)

### products

- glycerin
- cellulose
- demineralized water
- silica gel
- sodium dodecyl sulfate
- sodium fluoride
- preservative (facultative)
- coloring (facultative)
- aroma (facultative)

### material

- 1 measuring cylinder of 10 cm<sup>3</sup>
- 1 pot
- 1 measure (0,5 g of cellulose, sodium dodecyl sulfate)
- 1 paper hanky
- 2 spatulas
- 1 measuring cylinder of 25 cm<sup>3</sup>
- 1 measure (3g of silica gel)
- 1 stopped flask
- 1 label sticker

### operating procedure

- 1- measure 10 cm<sup>3</sup> of glycerin with the 10 cm<sup>3</sup> measuring cylinder
- 2- pour into the pot
- 3- add 1 skimmed measure of cellulose with a spatula
- 4- wipe the measure with the hanky
- 5- carefully mix with the same spatula to obtain a translucent liquid
- 6- let this spatula in the pot till the end
- 7- measure 20 cm<sup>3</sup> of demineralized water with the 25 cm<sup>3</sup> measuring cylinder
- 8- add 1 skimmed measure of silica gel with a clean spatula
- 9- carefully mix with the reserved spatula
- 10- do steps 8 and 9 again with 1 measure of silica gel
- 17- add 2 skimmed measures of sodium dodecyl sulfate with the clean spatula
- 18- add 5 drops of sodium fluoride
- 19- add 1 hint of spatula of preservative (facultative)
- 11- add 5 drops of coloring (facultative)
- 12- add 5 drops of aroma (facultative)
- 13- carefully mix the pot content
- 14- pour the pot content into a flask
- 15- block and label this flask

### remarks

- The prepared toothpaste is a **homogeneous mixture** of several products with different properties. Without preservative, it will be advised to store the toothpaste away from light and in a cool area and to throw it as soon as mould will appear.
- Glycerin is a wetting agent that is a product which maintains humidity in the mixture by preventing water to evaporate. The toothpaste will not dry so quickly and could be used longer.
- Cellulose enables components to link in the mixture.
- Silica gel is a **lightly abrasive powder**: it polishes teeth by rubbing them. Which abrasive material is used to polish wood for example?.....
- The **detergent** component in this toothpaste is the sodium dodecyl sulfate.
- **Sodium fluoride** brings fluorine that avoids tankteria growth in the mouth and protect teeth from decay.
- Teeth brushing with a brush clean by polishing and disperse the dirt with a detergent. Rinse with water carry the toothpaste and rubbish. It is reasnded to brush one's teeth after any meal.

# Making cosmetics

## C4. Soap preparation

(duration: about 1 hour - individual)

### products

- oil
- ethanol
- sodium hydroxide
- sodium chloride
- perfume (facultative)
- ice

### material

- 2 measuring cylinders of 25 cm<sup>3</sup>
- 1 pot (heat-resistant)
- 1 labeled flask
- 1 stove
- 1 spatula
- 1 measuring cylinder of 50 cm<sup>3</sup>
- 1 funnel
- 1 filter
- 1 pot (adapted to the funnel)
- 1 mould pierced with holes

### common material

- 1 ice bath
- 1 tank to heat water
- 1 stove to heat water
- 1 measure of 40cm<sup>3</sup> for boiling water

### operating procedure

While the educator heats water to boiling:

1. **measure** 20 cm<sup>3</sup> oil with the 25 cm<sup>3</sup> measuring cylinder
2. **pour into** the pot
3. **measure** 20 cm<sup>3</sup> ethanol with the other 25 cm<sup>3</sup> measuring cylinder
4. **pour into** the pot
5. **add** all the packaged solution of sodium hydroxide
6. **switch** the stove on
7. **place** the heat-resistant pot on the stove
8. **mix** without stopping with the spatula till obtaining a thick paste
9. **switch** the stove off
10. **place** the pot in the ice bath till cooling of the mixture
11. **take** the pot out of the ice bath
12. **let** the educator add 40 cm<sup>3</sup> boiling water in your pot
13. **carefully mix** with the spatula
14. **cool** the mixture in the ice bath
15. **add** 50 cm<sup>3</sup> of sodium chloride solution measured with the 50 cm<sup>3</sup> measuring cylinder
16. **add** 20 drops of perfume (facultative)
17. **carefully mix** the pot content
18. **place** a filter in the funnel
19. **put** the funnel on the flask
20. **slowly pour**, along the spatula, the pot content into the filter
21. **wait** till the liquid has run
22. **place** the remaining paste in the mould with the spatula
23. **let dry** this paste in the mould several days
24. **turn out** the soap when it is hard enough

### remarks

- The prepared soap is a **detergent**.
- On the contrary to make-up, lipstick and toothpaste, soap is not a mixture of several unchanged products at the end of fabrication. It has been obtained by **chemical reaction**, the starting products being transformed in other products such as soap. This chemical reaction is called **saponification**.
- This transformation requires energy brought by heating: the saponification reaction is **endothermic**.

# Learning with a soap film

## S1. Soap bubbles liquid preparation

(duration: about 30 minutes - individual)

### products

- water
- liquid detergent
- glycerin

### material

- 1 measuring cylinder of 10 cm<sup>3</sup>
- 1 pot
- 1 spatula
- 1 measuring cylinder of 50 cm<sup>3</sup>
- 1 stopped flask
- 1 label sticker

### operating procedure

- 1- measure 4 cm<sup>3</sup> of liquid detergent with the 10 cm<sup>3</sup> measuring cylinder
- 2- pour into the pot
- 3- add 45 drops of glycerin
- 4- measure 40 cm<sup>3</sup> water with the 50 cm<sup>3</sup> measuring cylinder
- 5- pour into the pot
- 6- mix with the spatula till obtaining a homogeneous solution
- 7- pour the soap bubbles liquid into a flask
- 8- block and label this flask
- 9- let the liquid settle for several days before using it to make bubbles

### all kept proportions

- To realize the following experiment, a lot of soap bubbles liquid is required. Calculate the necessary quantities to prepare 270 cm<sup>3</sup> of this liquid. Fill the following table in:

Product	Volume used in this experiment (cm <sup>3</sup> )	Volume used for the following experiment (cm <sup>3</sup> )
water	40	
liquid detergent	4	
glycerin	1	
<b>Total: bubbles liquid</b>	45	270

### remarks

- Glycerin is a wetting agent that is a product which maintains humidity in the mixture by preventing water to evaporate. A soap bubbles liquid that contains glycerin will enable you to realize more resistant, more elastic and bigger bubbles.
- A soap bubbles liquid can be prepared with only water and liquid detergent: it is a soap water. However, its resistance would be lower than soap bubbles liquid with glycerin.
- A bubbles-blower can be built with a coated wire wound on itself.

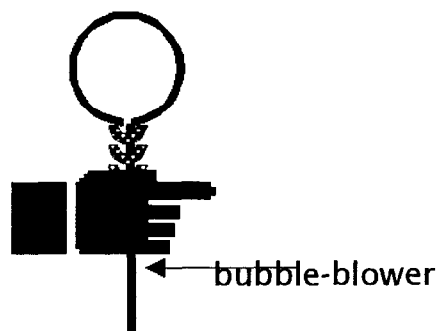

# Learning with a soap film

## S2. A soap film

(duration: about 30 minutes - individual)

### products

- water
- soap water

### material

- 2 tanks
- 1 trapeze

### operating procedure

1. completely dip the trapeze into a water tank
2. slowly take the trapeze out of the water tank
3. observe and complement the figure
4. restart with the trapeze in a soap water tank
5. observe and complement the figure

### observations

- Draw the trapeze threads and liquids in the following cases:

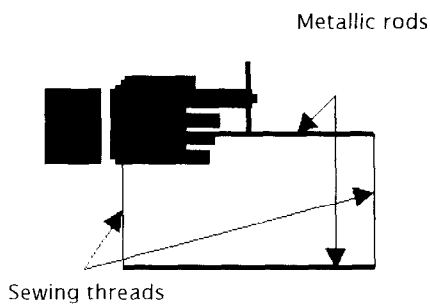

Dry trapeze

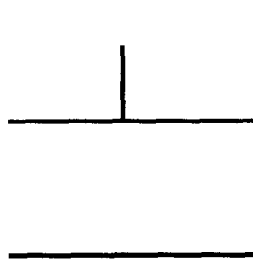

trapeze out of water

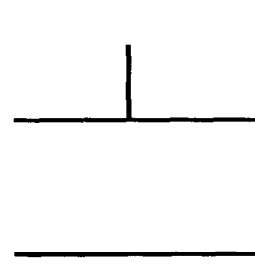

trapeze out of soap water

- Draw the detergent( ~~water~~ ) that introduces itself between soap film and surrounding air:

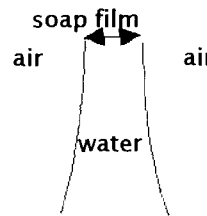
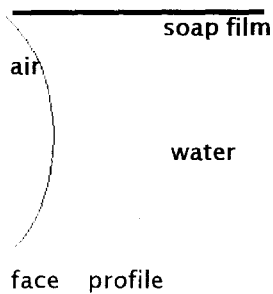

### remarks

- It would be worth doing "water has a "skin"" workshop before this one for the introduction to detergent properties.
- A soap film creates itself between the trapeze sides with the soap bubbles liquid. It is made of a thin membrane of water recovered by detergent that lies water by its hydrophilic part and the air by its hydrophobic one. Its thickness is higher at the bottom due to gravity.
- The soap bubbles liquid contains a liquid detergent that lowers water surface energy or surface tension. This explains why the soap film surface is smaller than the trapeze one when held in the air.

# Learning with a soap film

## S3. Soap film elasticity

(duration: about 5 minutes - individual)

### products

- soap bubbles liquid

### material

- 1 tank
- 1 trapeze
- 1 straw

### operating procedure

- 1- completely dip the trapeze into the soap bubbles liquid tank
- 2- dip two fingers into the soap bubbles liquid
- 3- pull the trapeze lower rod with these two fingers to retrieve maximal surface trapeze (as without the soap film )
- 4- push the trapeze lower rod with these two fingers to reduce surface trapeze once again

### remarks

- When the trapeze lower rod is pulled to retrieve the initial surface, a "work" is undertaken to compensate soap film surface energy: this is a positive work, physically.
- When the trapeze lower rod is pushed to reduce the soap film surface again, a "work" is undertaken to emphasize soap film surface energy: this is a negative work, physically.

## S4. Minimal surfaces and soap film

(duration: about 5 minutes - individual)

### products

- soap bubbles liquid

### material

- 1 tank
- 1 trapeze
- 1 straw

### operating procedure

- 1- completely dip the trapeze in the soap bubbles liquid tank
- 2- dip a straw end into the soap bubbles liquid
- 3- carefully blow in the straw place on the formed soap film
- 4- observe the obtained form

### observations

- What is the geometrical form obtained when one blows on the soap film?  
.....
- How is usually called the obtained form?  
.....
- Why do you think a trapeze has not been obtained using the trapeze framework?  
.....
- Justify the obtained form, knowing that the soap film takes the form requiring the minimal surface for a maximal volume of insufflated air.  
.....

### remarks

- The soap film always takes the more stable form with minimal surface.
- Engineers and architects use this soap film property to determine which structure will be optimal, that is with the maximum of stability and using the minimum of material. The soap film gives the answer as well as mathematical models requiring a computer (and even quicker).
- It is possible to make any wire structures to find their minimal surface with soap bubbles liquid, for example a cube, a tetrahedron, a octahedron, a spiral, or any other form.

# Learning with a soap film

<b>S5. Soap film auto-cicatrizacion</b>	(duration: about 30 minutes - individual)
---	---

- products**
- water
  - soap bubbles liquid
- material**
- 1 tank
  - 1 trapeze
  - 1 straw

- operating procedure**
1. dip the trapeze into the soap bubbles liquid
  2. try to pierce the formed soap film with a dry straw
  3. observe and note your remarks
  4. dip the trapeze into the soap bubbles liquid
  5. dip a straw end into the soap bubbles liquid
  6. try to pierce the formed soap film with a dry straw end
  7. observe and note your remarks

- observations**
- Why does the dry straw pierce the soap film?  
.....
  - Does a straw recovered with soap bubbles liquid pierce the soap film ?  
.....

- remarks**
- The soap film has been pierced by the dry straw. With the straw wetted by the soap bubbles liquid, the film is pierced but repairs itself with soap bubbles liquid brought by the straw: it is the soap film auto-cicatrizacion.

<b>S6. Soap film and bubbles iridescence</b>	(duration: about 5 minutes - individual)
--	--

- products**
- soap bubbles liquid
- material**
- 1 tank
  - 1 trapeze
  - 1 straw
  - 1 bubbles-blower

- operating procedure**
1. completely dip the trapeze into the soap bubbles liquid
  2. carefully observe the soap film till it bursts
  3. completely dip the bubbles-blower into the soap bubbles liquid
  4. dip a straw end into the soap bubbles liquid
  5. realize a big bubble
  6. carefully observe the bubble till it bursts

- observations**
- Which colors can you observe on the soap film and bubble?.....  
.....
  - Which is the color you observe on the soap film and bubble just before they burst?  
.....

- remarks**
- The soap film has a thickness in the range of 0,01µm and 1µm (1 micrometer (µm) is equal to 10<sup>-6</sup> m) what corresponds to a thickness 10 000 and 100 times lower than one of a paper sheet.
  - Soap film thickness is more important at the bottom because of gravity.
  - Natural light is made of different colors radiation which form white light when all similarly directed. This one is reflected on thin soap film which decomposes it depending on its thickness. Different colors iridescence appear as a result of certain interference between divers radiation. Irregular thickness soap film leads to color whirls. When the upper part of a film or a bubble becomes very thin, interference causes the subtraction of light, and so the apparition of black zones in the soap film. just before they burst.

# Using solar energy

## E1. Solar energy

(duration: about 30 minutes - individual pr in group)

### products

- water

### material

- 2 black stopped pots
- 1 measuring cylinder of 25 cm<sup>3</sup>
- 2 alcohol thermometers
- several mirrors (5 or more)

### operating procedure

- 1- measure 20 cm<sup>3</sup> water with the 25 cm<sup>3</sup> measuring cylinder
- 2- pour into one of the flasks
- 3- add the same quantity of water in the other flask
- 4- pierce a hole to introduce thermometer in each stopper
- 5- block the two flasks
- 6- expose the two flasks filled with water to the sun
- 7- place a thermometer in each flask
- 8- wait till temperature stabilizes
- 9- note water temperature
- 10- place mirrors en arc around flask n°2
- 11- let exposed to the sun for about 10 minutes
- 12- note water temperature in each flask

### observations

- Fill the following table. What is the role of mirrors?

Flask	n°1	n°2
Initial Temperature (°C)		
Final Temperature (°C)		

- Indicate the liquid level read on thermometers and the temperature at the end of the experiment:

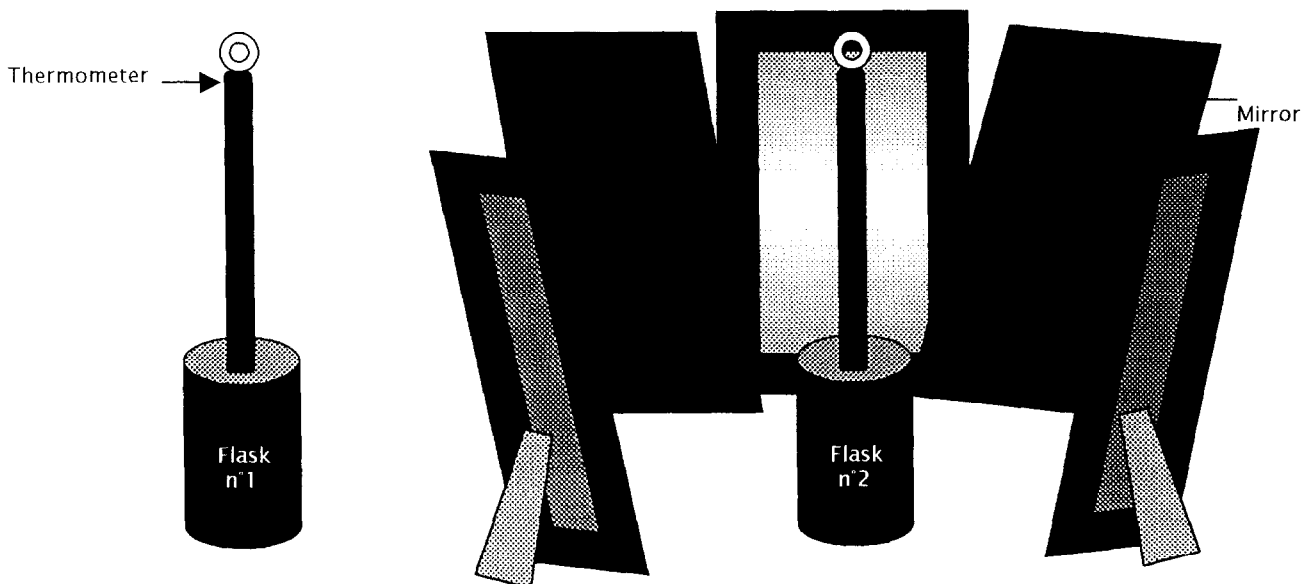

### Remarks

- Stars, such as the Sun, produce energy that is qualified as "renewable" on the opposite to fossil energies (coal, petrol, gas) based on limited resources compared to their exploitation rhythm.
- Quote several examples of renewable energy:  
.....
- Solar energy is transmitted in particular by light and can be transformed in calorific energy that means in heat.



# Using solar energy

## E2. Building a solar oven

(duration: about 30 minutes - individual or in group)

### products

- water

### material

- 1 car headlight reflector
- 1 wooden board
- 2 tassels (1 cm thick)
- 4 pins
- stopper
- glass tube in Pyrex
- 6 screws
- 2 washers

### operating procedure

1. pierce two holes diametrically opposed on the headlight reflector edge
2. introduce a wood screw in each hole, then a metal washer
3. fix screws in tassels
4. fix tassels to the wooden board
5. adapt a stopper in the heading hole reserved for bulb
6. place pins in the stopper to maintain a glass tube
7. introduce the other end in one of the holes
8. direct the reflector to the Sun
9. place the tube base where sun radiation converge

### solar oven device

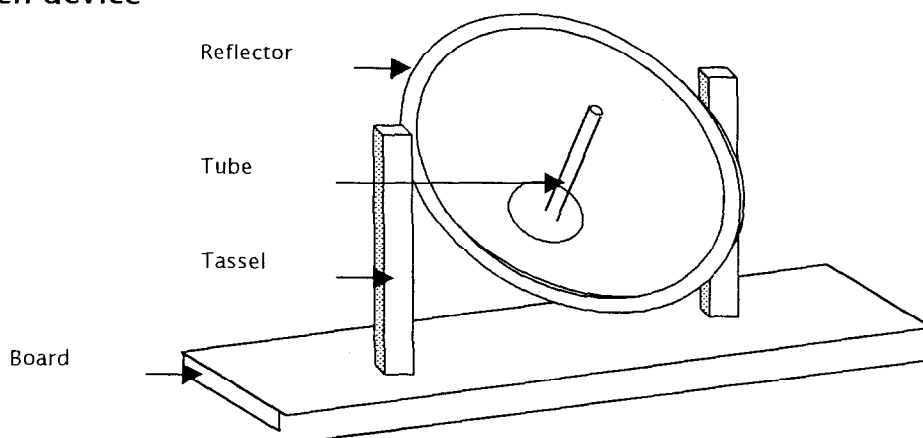

### Checking the good functioning of your solar oven

- How could you check the good functioning of your solar oven? Write an operating procedure and realize the experiment without forgetting to compare with a controlled test and fill the following table, for example.

In the tube	beginning	end
Water Volume (cm <sup>3</sup> )		
Water Temperature (°C)		
Time (min)		

### remark

- Solar oven using reflected solar light concentrated by mirrors provide high temperatures required for melting certain materials

# Using solar energy

## E3. Building of a solar water-heater (duration: about 30 minutes - individual or in group)

### products

- water
- black paint
- glue

### material

- 2 pots
- 1 box
- 1 polystyrene board
- corks
- 1 pane
- 1 black tube
- 1 clothes pin
- (1 alcohol thermometer)

### operating procedure

- 1- paint in black the box bottom
- 2- pierce two well spaced holes on a box side to introduce the tube
- 3- glue corks on the box bottom on one side and on the opposite one
- 4- pierce a hole in a pot to introduce the tube
- 5- drive a tube end in this hole
- 6- drive the other tube end in another hole
- 7- place the tube by winding it up around corks
- 8- drive a tube end out of the other box hole
- 9- place a tube end in the other pot
- 10- place a pin on the tube at the box exit
- 11- fix the pane in the polystyrene
- 12- place the polystyrene onto the box
- 13- fill the pot n°1 with water
- 14- let exposed to the sun for 1 hour
- 15- remove pin from the tube
- 16- let a little water run in pot n°2
- 17- replace pin onto the tube

### solar water-heater device

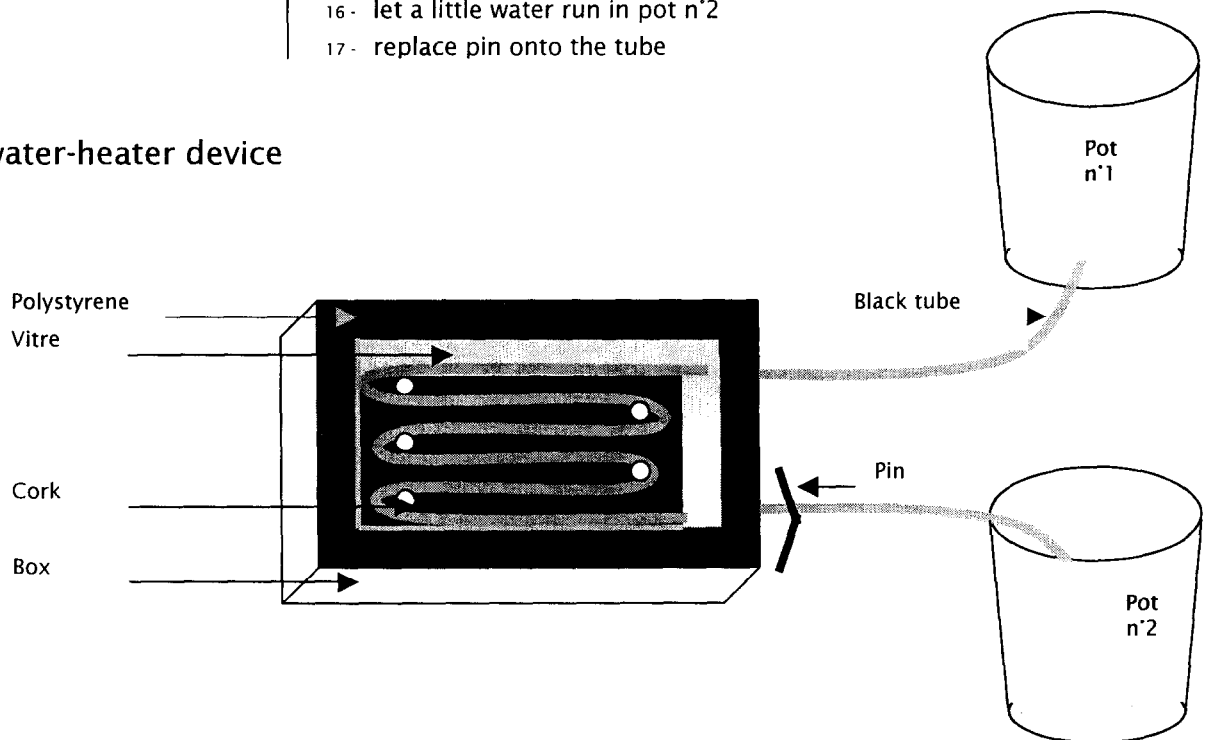

### checking the good functioning of your solar water-heater

- How could you check the good functioning of your solar water-heater? Write an operating procedure and realize the experiment without forgetting to compare with a controlled test.

### remark

- Solar energy can be used by solar captors that enable to store heat and to transmit it to water, for example.

# Using solar energy

## E4. Salt water desalinization

(duration: about 30 minutes - individual or in group)

### products

- demineralized water
- sodium chloride

### material

- 1 measuring cylinder of 50 cm<sup>3</sup>
- 3 pots
- 1 measure (1.5 g of sodium chloride)
- 1 spatula
- 1 large dish
- 1 plastic foil
- 1 stopper

### operating procedure

- 1- measure 50 cm<sup>3</sup> water with a measuring cylinder
- 2- pour into pot n°0
- 3- add a measure of sodium chloride
- 4- mix with the spatula till obtaining a homogeneous solution
- 5- pour salt water into the large dish
- 6- do steps 1 to 4 again in pot n°1
- 7- keep this mixture as controlled test
- 8- put the pot n°2 at the large dish center
- 9- place a plastic foil on the large dish
- 10- place a stopper above the plastic foil on pot n°2
- 11- expose the large dish to the sun till its content has evaporated
- 12- taste the pot n°2 content
- 13- taste the pot n°1 content

### observations

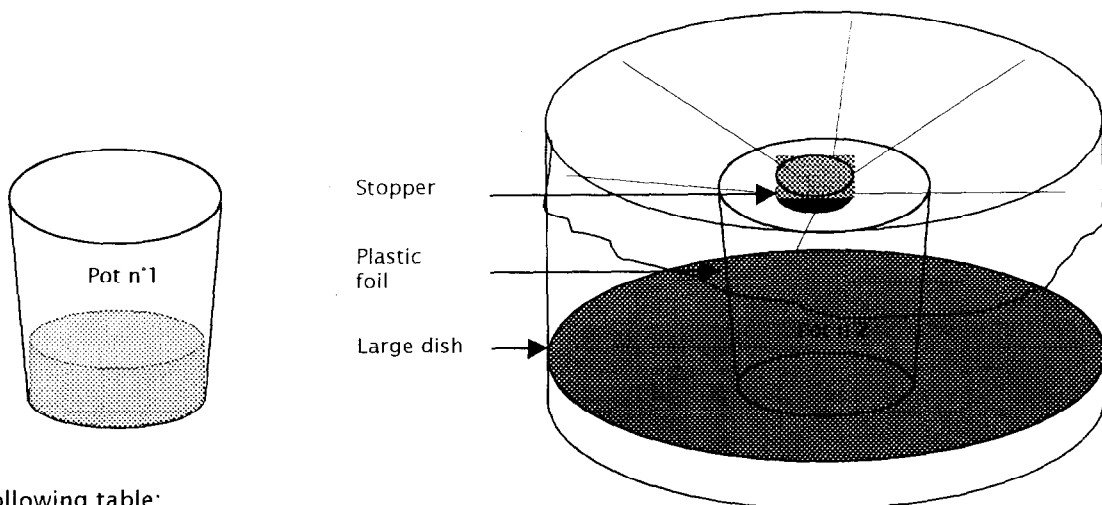

- Fill the following table:

Pot	n°1	n°2
Taste		

- What happened? .....
- Where is the introduced sodium chloride? .....

### remark

- Sodium chloride is the scientific name for salt. Sea water is salted. It contains between 30 and 35 grams of sodium chloride per liter, being between 1,50 and 1,75 grams for 50 cm<sup>3</sup> sea water.
- Sea water desalinization is a useful mean to produce soft water. But it requires a lot of energy.

# Making or recycling materials

## M1. Making buttons from milk

(duration: about 1 hour - individual)

### products

- water
- full-cream milk
- lemon juice (or vinegar)
- coloring (facultative)

### material

- 1 tank (heat-resistant)
- 1 stove
- 1 measuring cylinder of 25 cm<sup>3</sup>
- 2 pots
- 1 spatula
- 1 thin tissue (20cmx20cm)
- 1 stick (for buttons)
- 1 plastic foil

### operating procedure

1. prepare boiling water by heating water in a resistant tank placed on a stove
2. switch the stove on
3. measure 25 cm<sup>3</sup> of milk with the measuring cylinder
4. pour them into pot n°1
5. place the pot in boiling water
6. stir the pot content with the spatula till it has become mild (about 5 minutes)
7. switch the stove off
8. remove pot n°1 from boiling water
9. add 5 drops of coloring
10. mix with the spatula till obtaining a homogeneous solution
11. continuously stir with the spatula during the following step
12. very carefully pour, while stirring, a few drops of lemon juice in the mild milk till flakes appear, regroup themselves, and the liquid becomes suddenly translucent (between 10 and 20 drops)
13. place the thin tissue on a clean pot n°2
14. pour all the pot content n°1 into pot n°2
15. remove the tissue containing a paste comprised of casein
16. squeeze the obtained paste by carefully wringing the tissue out
17. form a ball with the obtained paste
18. knead the obtained paste with hands by forming balls
19. spread 1 or 2 balls on the plastic foil
20. form buttons by making two holes with the stick (or another form)
21. let dry till objects harden (a night)

### remarks

- The milk is composed of water (90% in mass), sugars (mostly lactose), proteins (see "W5. Cloth washing"), fats, minerals (calcium, phosphorus) and vitamins.
- About 85% of milk proteins are of casein, a heavy substance or surface-active "macromolecule" (see "W2. water has a "skin"). What is the role of casein in milk (see "W4. Interest of detergents")?  
.....
- The milk coagulates when salt or acid products are added, such as lemon juice or vinegar: milk then curdles when casein separates from milk. Casein proteins have been denatured by the addition of lemon juice (citric acid) or vinegar (acetic acid). The acidity of stomach makes proteins coagulate and then slow their digestion because they become less available to enzymes (see "W5. Cloth washing").
- Cow milk contains more proteins than human milk, coagulation being easier with cow milk, but making it also less digest than human milk.
- Milk coagulation is the first step in the preparation of cheeses, before their wringing out, salting and refining. By liberating lactic acid from the transformation of sugar milk (lactose), lactic bacteria acidify the media and coagulate milk: proteins agglomerate to form a "curdle" that leads to yoghourts.
- One of the first plastics was made from casein and formaldehyde (to make the material plastic and insoluble): it was called "milkstone" (casein-formol or "Galalith"). Galalith is still prepared to make buttons and luxurious pen.

# Making or recycling materials

## M2. Making a brooch of synthetic resin

(duration: about 30 minutes - individual)

### products

- Formaldehyde
- Urea
- concentrated chlorhydric acid
- coloring (facultative)

### material

- 1 measuring cylinder of 25 cm<sup>3</sup>
- 1 pot
- 1 spatula
- 1 safety pin (for a brooch)
- 1 plastic foil

### precautions

- wear a lab-cloth, gloves, goggles
- handle in a ventilated area
- use a "pro-pipette" for concentrated acid

### operating procedure

1. measure 15 cm<sup>3</sup> of formaldehyde with the measuring cylinder
2. pour them into the pot
3. add 5 drops of coloring
4. dissolve urea until formaldehyde saturation without heating
5. stir the pot content till urea can not dissolve anymore (about 5 minutes)
6. add drop to drop, under stirring, few drops of concentrated chlorhydric acid, till the pot content forms a solid (about 5 minutes)
7. stir with the spatula until a resin forms and cools
8. place this resin, with the spatula, on a plastic foil
9. form a brooch by pressing the safety pin on the resin
10. let dry until the object hardens (a night)

### remarks

- Urea-formol resins preparation by urea condensation with formaldehyde was discovered in 1920.
- Shiny plastics obtained are part of aminoplastic resins, and are used in particular as glues, varnishes, textile finishing.

# Making or recycling materials

## M3. Making a plastic film (duration: about 30 minutes - individual)

### products

- demineralized water
- polyvinyl alcohol (PVA)

### material

- 1 measuring cylinder of 25 cm<sup>3</sup>
- 1 measure (1,3g of PVA)
- 1 pot (heat-resistant)
- 1 spatula
- 1 stove
- 1 plate (20cm x 20cm)

### operating procedure

1. **measure** 25 cm<sup>3</sup> water with the measuring cylinder
2. **pour** into the pot
3. **add** 1 skimmed measure of PVA with a spatula
4. **switch** the stove **on**
5. **place** the heat-resistant pot on the stove
6. **carefully mix** until obtaining a translucent solution
7. **remove** the pot from the stove
8. **switch** the stove **off**
9. **spread** the pot content in very thin layer on the plate
10. **let dry** this film during one day  
(or : place in an oven at 175°C for about 15 minutes and let dry until the film hardens)

### remarks

- Polyvinyl alcohol (PVA or Elvanol) is a **polymer** that was made from a petroleum product, polyvinyl acetate. It is used to make **plastic objects**.
- Plastics can be obtained:
  - from natural substances (Galalith, Celluloid, Cellophane, etc.)
  - from synthetic substances (condensation resins (Bakelite, Nylon, polyurethane), polymerization resins (Plexiglas, Araldite), silicones, etc.)
- Materials prepared by humans are **synthetic products**, whereas **natural materials** (bones, horns, ivory, tortoiseshell, gelatin, natural resins, etc.). Galalith was prepared to imitate corn and ivory.
- **Synthetic plastics** tend to replace any natural product in daily life and industrial applications, due to their advantageous properties. Their main inconvenient is their **recycling** that is often problematic.
- PVA is soluble in water. It is the reason why a lot of **packaging** dissolve in water. For example, it is used to directly place dirty clothes in washing machines because the plastic will dissolve in hot water: thus hospital staff contamination can be prevented.
- In agriculture, in order to prevent contact between skin and toxic pesticides, PVA bags containing pesticides doses are laid down cultures that will liberate the chemical after plastic dissolution into water.
- What will happen if your plastic film is in contact with water ?  
.....
- Write an operating procedure and realize the experiment to check your hypothesis.

# Making or recycling materials

## M4. Making a polyurethane foam

(duration: about 10 minutes - individual)

### products

- di-isocyanate of 4-4'-di-phenylmethane (MDI)
- mixture of polyol and expanding agent

### material

- 1 filter paper foil
- 2 pots
- 1 spatula

### precautions

- wear a lab-cloth, gloves, goggles
- handle in a ventilated area

### operating procedure

1. place both pots on the filter paper foil
2. pour about 1 cm height of polyisocyanate into pot n°1
3. pour about 1 cm height of mixture of polyol and expanding agent into pot n°2
4. pour the pot content n°2 into pot n°1
5. mix with the spatula until obtaining a homogeneous mixture
6. wait a minute and observe without touching during 3 minutes
7. you can then touch the produced foam

### observations

- What happened? .....
- How is the foam? .....
- Is pot n°1 content warmer or colder at the end of experiment? .....

### remarks

- Polyurethane preparation is obtained by mixing polyisocyanate and polyol, respectively isocyanate and alcohol polymers. The expansion as a foam is due to the expanding agent that is vaporized in the atmosphere during the chemical reaction.
- Depending on the polyol used, a smooth foam or a rigid foam can be obtained.
- Polyurethane are very spread polymers. They are used in particular for isolating houses and seat stuff in automobile industry.
- **WARNING:** Polyurethane foam shall never be burnt as it produces a lethal gas, hydrogen cyanide.

# Making or recycling materials

<b>M5. Recycling paper</b>	(duration: about 30 minutes - individual)
----------------------------	---

## products

- water
- old newspapers

## material

- 1 large plate
- 1 spatula
- 1 measure
- 1 grille
- 1 tank
- 2 absorbent tissues
- 1 roller
- 1 cloth thread
- 2 pins

## operating procedure

1. tear the newspapers up above a large plate
2. add water
3. mix\* the paper paste with the spatula
4. let the paper paste settle during the night
5. take a measure of paper paste
6. place the grille on a tank
7. spread the paper paste with the spatula in a very thin layer on the grille
8. place the grille between two absorbent tissues
9. squeeze the grille with the roller
10. let paper dry by suspending it to a cloth thread with pins

\*The paper quality will be better with a food mixer to mix the paper paste.

## remarks

- Paper is a material made of natural vegetal fibers, in particular of wood fibers.
- How many tons of paper does your country produce annually?  
.....
- To produce one ton of paper, about 17 trees are necessary, on the average. How many trees are required for the annual production of paper in your country?  
.....



## FURTHER READING

### Girls and science and technology education

- Botswana Government (1990) *Women in science and technology*. Science and Technology Roadshow in Botswana, 12-18 August 1990. Ed. Botswana Government Printer, Gaborone, 36p.
- Erinosh, Stella (1997) *Participation des femmes aux sciences : une analyse des matières au programme des sciences de l'enseignement secondaire*. Ed. Academy Science Publishers, Nairobi, Rapport Abrégé de Recherche, **29**, 23p.
- Rajabu, A. R.M.S. & Chedi, R.W. (1997) *Femmes et filles des communautés locales tanzaniennes : connaissances, attitudes et pratiques sur l'environnement*. Ed. Academy Science Publishers, Nairobi, Rapport Abrégé de Recherche, **35**, 9p.
- Unesco (1997) *Innovations in Science and Technology Education*. (eds:) Jenkins, Edgar W. & Layton, David. Ed. Unesco Publishing, Paris, Vol. VI, 286p.
- Unesco (1992) *Formation scientifique des filles. Un enseignement au-dessus de tout soupçon?* (ed.) Renée Clair. Ed. Unesco Publishing, Paris.
- Zietman, Aletta (1997) *Les cours de mathématiques et de sciences pour les filles : une étude menée au Malawi et en Afrique du Sud*. Ed. Academy Science Publishers, Nairobi, Rapport Abrégé de Recherche, **28**, 19p.

### Scientific themes of the document

- Groupe de Recherche en Didactique de la Chimie et quelques enseignants (1990) *Pour une approche méthodologique des sciences expérimentales à l'école primaire : les matières plastiques*. Ed. Centre Régional de Documentation Pédagogique de Poitou-Charentes, 31p.
- Groupe de Recherche en Didactique de la Chimie et quelques enseignants (1989) *Comment fabriquer quelques produits courants ?* Ed. Centre Régional de Documentation Pédagogique de Poitou-Charentes, 84p.
- Groupe de Recherche en Didactique de la Chimie et quelques enseignants (1987) *Manipulations à la portée de tous*. Ed. Centre Régional de Documentation Pédagogique de Poitou-Charentes, 198p.
- Maury, Jean-Pierre (1987) *Les bulles, qu'est-ce que c'est ?* Ed. Ophrys, Collection du Palais de la Découverte, Paris, 93p.
- Katz, David (1991) Soap bubbles 1: solutions and basic tools (March 1991). Soap bubbles 2: why bubbles bounce (May 1991). Soap bubbles 3: the chemistry of a soap bubble (July 1991). Soap bubbles

4: why soap bubbles break and why they are spherical (September 1991). Soap bubbles 5: shapes and colours (November 1991). *Education on chemistry*. 5p.

- Nachtigall, W. (1987) *La nature réinventée*. Ed. Plon.
- This, Hervé (1993) *Les secrets de la casserole*. Ed. Belin. 222p.
- Wick, Walter (1998) *Gouttes d'eau*. Ed. Millepages, 40p.

#### Other:

- Azar Khalatbari avec Graine de Chimiste (1994) La chimie des farces et attrapes, *Science et Vie Junior*, avril 1994, **58**, pp.18-21.
- De Gennes, Pierre-Gilles & Badoz, Jacques (1994) *Les objets fragiles*. Ed. Librairie Plon. 262p.
- Graine de Chimiste (1995) Dis... pourquoi, *Sciences et Avenir*, avril-mai 1995, hors série, **100**, pp.50-51 (*Les secrets de l'encre invisible*), 64-65 (*La formule du "Slime"*) et 72-75 (*Sous la douche...*).
- Groupe de Recherche en Didactique de la Chimie, Graine de Chimiste et quelques enseignants (1997) *Pour une approche expérimentale de l'eau*. Ed. Centre Régional de Documentation Pédagogique de Poitou-Charentes, 129p.
- Groupe de Recherche en Didactique de la Chimie et quelques enseignants (1990) *Comment faire un spectacle de chimie ?* Ed. Centre Régional de Documentation Pédagogique de Poitou-Charentes, 65p.
- Groupe de Recherche en Didactique de la Chimie et quelques enseignants (1985) *Introduction des sciences expérimentales à travers la chimie dans l'enseignement primaire : étude de la notion d'acidité*. Ed. Centre Régional de Documentation Pédagogique de Poitou-Charentes, 67p.
- Lutfi, Mansur (1988) *Cotidiano e educação em química*. Ed. Livraria Unijuí Editora, Ijuí, Brésil, 224p.
- Matricon, Jean & Palais de la Découverte (1990) *Cuisine et molécules*. Ed. Hachette Jeunesse, **78**, 77p.
- Les petits débrouillards (1989) *40 expériences faciles à réaliser*. Ed. Belin, **3**, 77p.
- Thibault, Janine, Davous, Dominique & Masson, Arlette (1993) Une approche interactive de la chimie. *Didaskalia*. **2**, pp.121-130.
- Unesco (1974) *Nouveau manuel de l'Unesco pour l'enseignement des sciences*. Ed. Unesco Publishing, Paris, 281p.